

# Jungheinrich Electric pedestrian Pallet Truck Swift Capacity 3000 lb

## EME 12



- **Fully electric with AC travel drive**
- **Compact as a hand pallet truck**
- **Built-in charger**
- **Easy handling with handle in upright position through crawl speed button**

The Jungheinrich EME electric pallet truck, with its compact design and use of AC technology, makes horizontal transportation quick and easy.

**Operator Area:** The low hinged handle in combination with a low overall truck height ensures a high degree of safety and optimum fork tip visibility.

**Handle Head:** The multifunction handle head with exemplary ergonomics provides optimum operating comfort and maximum safety. The operating buttons for lifting/lowering function, as well as the horn can be reached with minimum hand movement.

**Drive/Lift Motors:** A 0.3 kW AC motor powers the forward and reverse speeds, while a 0.4 kW DC pump motor raises and lowers the load. An

AC motor offers more power from a smaller motor, while using less energy. In addition, an AC motor is virtually a maintenance free system, as it does not require the use of traditional contactors or brushes.

**Battery:** 2 x 12 V/42 Ah maintenance-free with Gel/Fleece technology. Battery discharge indicator is a standard option.

**Battery Charger:** The build in charger is micro-processor controlled. It includes a charge control light, and compensating and maintenance charge features. May be connected to any 120-Volt outlet for charging.

**Drive Control:** Precise, sensitive acceleration and braking. Regenerative braking system by releasing the drive switch. Wearfree and energy saving reverse current brake.

**Wheels:** Standard with polyurethane tires.

Drive wheel: 9.1 inch dia. 2.5 inch wide.

Load Wheels: 2.95 inch dia., 3.7 inch wide.

**Steering:** Easy handling through long, low hinged safety handle, which can be swiveled 180°.

**Brake:** Electro-magnetic brake, acting directly on the motor shaft. Crawl speed button ensures safe maneuvering in confined spaces while the handle is in the upright position. During this process, the brake is released automatically and travel speed is significantly reduced.

**Forks:** Torsion-rigid, 6 inch wide.

**Ease of servicing:** Easy, direct access to all components.



ISO-9001, ISO-14001-  
Certification of the Quality and  
Environment Management

# JUNGHEINRICH

## Performance Data

Capacity		3000 lb	1360 kg
Travel Speed	without load	3.1 mph	5.0 km/h
	with rated load	2.6 mph	4.2 km/h
Lifting speed	without load	5.9 ft/min	3.0 cm/s
	with rated load	3.9 ft/min	2.0 cm/s
Max. gradient performance	without load	15.0 %	15.0 %
	with rated load	3.5 %	3.5 %
Service weight with 42 Ah battery		364 lb	165 kg

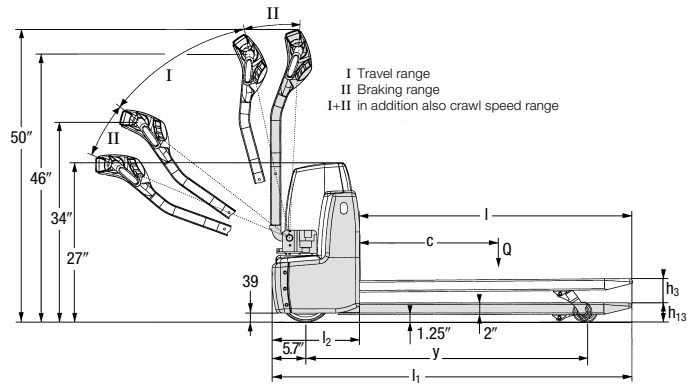

## Technical Data

Q	— Capacity	3000 lb	1360 kg
s	— Load center	24.0"	600 mm
y	— Wheelbase	48.0"	1218 mm
b <sub>1</sub>	— Overall width	27.6"	700 mm
l <sub>2</sub>	— Drive unit length	14.9"	378 mm
l <sub>1</sub>	— Truck length	61.2"	1555 mm
b <sub>5</sub>	— Width across forks	20.5/25.6"	520/650 mm
e	— Fork width	5.9"	150 mm
b <sub>11</sub>	— Track width load section	14.6/19.7"	370/500 mm
h <sub>13</sub>	— Lowered height at tip of forks	2.95"	75 mm
h <sub>3</sub>	— Lift	3.74"	95 mm
Wa	— Turning radius	56.1"	1425 mm
a	— Safety clearance	8.0"	200 mm
l	— Standard fork length	46.3"	1177 mm

Subject to technical modifications without notice.

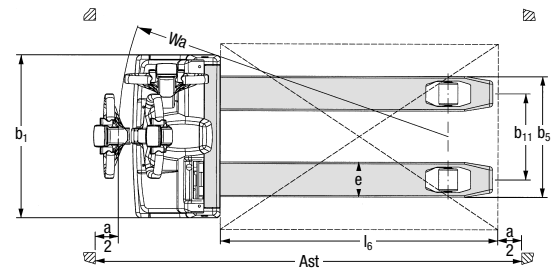

## Working aisle widths (inch)

Pallet size	Position	Ast incl. 8.0" safety clearance
32.0" x 48.0"	Lengthways	72.4"
40.0" x 48.0"	Sideways	64.6"