

Jungheinrich

High Rack Stacker/Order Picker

Capacity 3300 lb

ETX-Kombi ac 150 K



- **3 Phase AC drives with high efficiency**
- **Energy reclamation during lowering and braking**
- **Elevating operator cabin**
- **Swivelling forks for load pick-up direct from the floor**
- **Total lift height up to 37 ft**

The trucks of the ETX-Kombi ac range cover two basic functions: the stacking and retrieval of complete pallets and the order picking of individual articles from the racking. Operator cabin and load are raised together so that at all times optimum visibility of the forks and the racking is ensured. The swivelling forks can pick up pallets direct from the floor and stack/retrieve them to the left and right in suitable racking installations. Due to the alternatives of mechanical or inductive guidance the ETX-Kombi ac requires a minimum working aisle width.

Driver Position: The spacious cabin is designed for operation in standing as well as in sitting position. All control elements are conveniently integrated into the steplessly adjustable central control panel. The operator receives important truck information via a display in front of him. All functions are controlled via two switches and special push buttons. The firm hand rests provide optimum stability during movement of the truck. The sprung seat is adjustable to the body size of the driver. In the folded-up position it serves as a back rest during standing operation. Together with the upper safety bars, the foot guard also folds upwards to give the operator a clear and comfortable entrance.

Load Handling Device: The swivelling forks can pick up unit loads at the side or at the front direct from the floor. All customary loading aids may be used. As standard, the forks can be sideshifted into the required position to the left

or to the right of the aisle or sideshifted and rotated simultaneously by manual control. As an option automatic synchronisation is available. All fork movements are steplessly controlled via proportional valves and have adjustable cushioning during starting and on reaching the end position. The ETX-Kombi ac can also be supplied with telescopic forks.

Travel Drive: 7.000 Watt (1 hour rating) 3 phase AC motor with high torque. High thermal stability. Two years warranty.

Drive Control: Stepless, sensitive regulating of the travel speed via impulse control in MOSFET technology. The travel speed is determined by more or less movement of the right hand switch on the central control panel. On releasing the lever, the truck is braked regeneratively and the released energy is fed back into the battery or to other assemblies.

Wheels: Drive wheel dia. 15.8 x 6.3", load wheels dia. 15 x 7.5". All wheels with Vulkollan tyres.

Brake: As operating brake the truck protecting regenerative motor brake is used, at high speeds in addition the electro-magnetically lifted spring pressure brake on the drive wheel comes into effect. This also acts as parking brake. During emergency braking, hydraulic load wheel brakes are also activated.

Steering: Easy moving electro-hydraulic steering. On switching on the truck, automatic straightening of the drive wheel.

Hydraulics: Pump unit with powerful 20.000 Watt (S3 25 %) 3 phase AC motor. All hydraulic movements are sensitively controlled via impulse control in MOSFET technology. On lowering the cabin the lift motor changes over to generator operation and the released energy is fed back into the battery or other assemblies.

Lift Mast: Two-stages masts (ZT) or three-stage masts with full free lift (DZ). Excellent torsion resistance. Externally placed cylinders provide free visibility through the mast.

Battery: 80 V/420, 560 Ah. 72 Volt system on request.

Easy Servicing: All units are quickly accessible through easily opened, detachable covers. An integral diagnostic system permits fast fault finding and elimination. Numerous performance parameters can be checked and adjusted immediately via PC by Service, thanks to the latest BUS technology.

Options: Inductive guidance, data communication, application related cabin and swivelling fork dimensions.

Safety: The truck conforms to the CE guidelines for industrial trucks.



ISO-9001, ISO-14001 -
Certification of Quality and
Environment Management.

JUNGHEINRICH

ETX-Kombi ac 150K

Performance Data

referring to a truck with rail-guidance

Capacity at c = 600 mm (24")		1500 kg	3300 lb
Travel speed	without load	10.5 km/h	6.5 mph
	with load	10.5 km/h	6.5 mph
Lifting speed, main lift	without load	0.47 m/s	92.5 ft/min
	with load	0.42 m/s	82.7 ft/min
Lifting speed, auxiliary lift	without load	0.35 m/s	68.9 ft/min
	with load	0.30 m/s	59 ft/min
Lowering speed, main lift	without load	0.40 m/s	78.7 ft/min
	with load	0.40 m/s	78.7 ft/min
Lowering speed, auxiliary lift	without load	0.20 m/s	39.4 ft/min
	with load	0.30 m/s	59 ft/min
Service weight incl. battery		6900 kg	15200 lb
Battery compartment size and weight		1060 x 720 x 880 (1558 kg)	41.7 x 28.3 x 34.6" (3430 lb)

Dimensions

Truck dimensions referring to pallet 48 x 48" and 2-stage mast (further dimensions on request)

	mm	inch
c — Load centre	600	24.0
x — Load distance	409	16.1
y — Wheelbase	1926	75.8
z — Rear edge truck-drive axle	280	11.0
h ₁ — Closed mast height	see table	see table
h ₃ — Lift	see table	see table
h ₄ — Extended mast height	see table	see table
h ₆ — Height of overhead guard	2550	100.4
h ₇ — Standing height	470	18.5
h ₉ — Auxiliary lift	1740	68.5
— closed height auxiliary lift	2550	100.4
l — Fork length	1200	47.2
s — Fork thickness	50	2.0
e — Fork width	125	4.9
l ₁ — Overall length without load *	3747	143.6
l ₂ — Length incl. back of fork *	3452	132.0
l ₆ — Stacking-in depth	1210	47.6
l ₈ — Pivot point - load wheel axle	1101	43.3
b ₁ — Chassis width	1220	48.0
b ₂ — Width across load wheel axle	1550	61.0
b ₅ — Width across forks (adjustable)	798	31.4
— Width across guide rollers	1690	66.5
— Reach	1300	51.2
b ₁₂ — Pallet width	1220	48.0
b ₁₄ — Cabin width	1440	56.7
Ast — Working aisle width, rail-guided	see table	see table
Wa — Turning radius	2200	86.7
m ₂ — Ground clearance centre wheelbase	85	3.3

* with three stage masts + 1.2" (+30 mm)

Working Aisle Width

	mm	inch
Pallet size	1016 x 1220	40 x 48
Stacking-in depth	1220	48.0
Ast- Aisle width, rail-guided	1690	66.5
Ast- Aisle width, wire-guided	1740	68.5
Ast ₃ - Transfer aisle *	3900	153.5

* practical transfer aisle width +20" (+500 mm) with rail-guidance

* practical transfer aisle width +40" (+1000 mm) with wire-guidance

Right to make changes and technical improvements reserved.

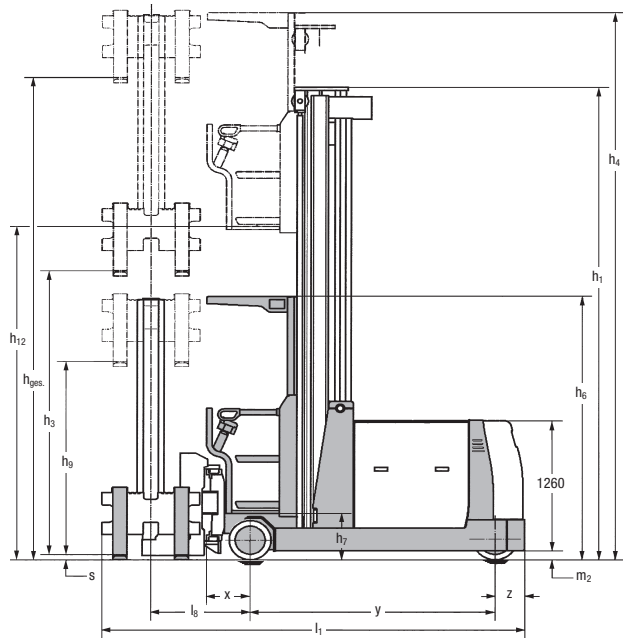

Standard Lifting Mast Designs

Two-stage masts – ZT

h ₃	h ₃ + h ₉	h ₁	h ₄
mm	mm	mm	mm
3500	5240	2955	6050
4000	5740	3205	6550
4500	6240	3455	7050
5000	6740	3705	7550
5500	7240	3955	8050
6000	7740	4205	8550
6500	8240	4555	9050
7000	8740	4805	9550
7500	9240	5055	10050
8000	9740	5305	10550
8500	10240	5655	11050
9000	10740	5905	11550
9500	11240	6155	12050

Three-stage masts – DZ

h ₃	h ₃ + h ₉	h ₁	h ₄
mm	mm	mm	mm
4500	6240	2695	7050
5000	6740	2895	7550
5500	7240	3095	8050
6000	7740	3295	8550
6500	8240	3495	9050
7000	8740	3695	9550
7500	9240	3895	10050
8000	9740	4095	10550
8500	10240	4295	11050
9000	10740	4495	11550
9500	11240	4695	12050

